

GRADALL® XL 5130 V



RAILWAY
MAINTENANCE
MACHINE



SPECIFICATIONS

Engine

- Volvo TAD873VE Tier 4f 7.7L diesel with selective catalytic reduction and cooled EGR technology

Gross Rating: 315 hp @ 2200 rpm, 958 ft lb torque @ 1200-1700 rpm

Net Rating: 295 hp @ 2200 rpm

- Four cycle, inline six cylinder, liquid cooled
- Turbo charge air after-cooled
- Off-road certified, electronically controlled, grid heater
- Vertical canister style lube and main filters attached to engine
- Volvo remote mount vertical style fuel/water separator with water in fuel indicator, alarm and manual feed pump
- Block heater

Air Filter

- Two-stage Donaldson PSD PowerCore with high efficiency pre-cleaner, vacuator valve and remote service indicator

Electrical System

- 24 volt, 110 amp alternator with integral voltage regulator, two SAE #C31-S 1000 CCA batteries
- Battery switch lockout tagout

Fuel Tank Capacity: 100 gal (378 L)

Urea Tank Capacity: 11.9 gal (45 L)

Chassis Cooling Package

- Three aluminum bar-plate type coolers stacked vertically
- Air to air charge air cooler, radiator and a transmission cooler
- All coolers backed by a molded fan shroud, engine mounted fan ring and 26.8" 9-blade fan driven by a Volvo electronically controlled variable speed fan drive

Gear Speeds

Gear	1	2	3	4	5	6	REV
MPH	6.3	16.2	24.1	37.4	50.6	59.5	6.4
Km/hr	(10.1)	(26.1)	(38.8)	(60.2)	(81.4)	(95.8)	(10.3)

Drivelines

- Spicer 1710 Series with "half round" yokes

Transfer Case

- (6 x 4) Cushman Model 479-1, 1:1 ratio, pneumatic engage for remote propel

Upperstructure Cab

- All-weather cab isolated from frame on rubber mounts
- Tinted safety glass windows
- Skylight
- Acoustical lining
- Four-way adjustable seat
- Dome light
- Filtered air heater and defroster
- AM/FM radio
- Air conditioning
- LED work light package
- Heat source provided by a fast response, closed circuit hydraulic heater with 20,000 BTU/Hr. capacity
- Front window slides to overhead storage
- Mirrors on right and left sides
- Windshield wiper and washer
- Operator's seat belt
- FRA spec 360 degree strobe light
- Dual air horn
- Upper air horn

Upperstructure Controls

- Two electronic joysticks (hoist and bucket, telescope and swing)
- One rocker switch (tilt) control
- Joysticks mounted on arm pods, adjustable for individual operator comfort and convenience
- Quick change joystick pattern switch (Gradall, SAE, Deere) located on instrument panel
- Two foot pedals for remote control of undercarriage steering
- Travel and digging brakes
- Self-centering joysticks and pedals; when controls are released, power for movement disengages and swing and travel brakes set automatically
- AREMA decals

Engine Controls

- Key ignition switch with neutral start
- Indicator lights for low air, engine status, park brake, travel status, hydraulic fluid temperature and level
- Automatic engine shutdown occurs with low oil pressure
- Derate/shutdown for oil temperature, coolant temperature, coolant level, ERD temperature, charge air temperature, charge air pressure and derate for SCR temperature

Boom

- Two piece triangular telescoping boom
- Adjustable boom rollers with eccentric shafts
- 220° boom tilt
- 105° boom pivot angle
- Auxiliary hydraulics

Hydraulic System

Pumps

- One load-sensing axial piston pump; 0-77 gpm (0-291 41L/min) total
- One gear pump (pilot and cooling) 11 gpm (41 L/min)

SYSTEM SPECIFICATIONS

Eight Double Acting Cylinders

- One Boom Cylinder: 3.75" (95mm) bore x 2.75" (70mm) rod x 168" (4267mm) stroke
- Two Hoist Cylinders: 4.75" (121mm) bore x 3.347" (85mm) rod x 30.5" (775mm) stroke
- One Tool Cylinder: 5.0" (127mm) bore x 3.0" (76mm) rod x 25.9" (658mm) stroke
- Rail gear cylinders

Three Hydraulic Motors

- Swing, 68 Hp (51kW)
- Tilt, 21 Hp (16kW)
- Remote drive, 110 Hp (82kW) total

Operating pressures

- Hoist.....4,800 psi (331 BAR)
- Tilt.....2,500 psi (172 BAR)
- Swing.....4,500 psi (310 BAR)
- Tool.....4,800 psi (331 BAR)
- Telescope.....4,800 psi (331 BAR)
- Remote Propel.....4,800 psi (331 BAR)
- Pilot system.....500 psi (35 BAR)

Oil capacity

- Reservoir 50 gallons (189 L)
- System 70 gallons (265 L)
- Pressurized reservoir with visual oil level gauge

Filtration system

- 5 micron return filter with magnet
- 10 micron pilot filter
- Fin and tube-type oil cooler with thermostatically controlled cooling fan
- Pressure-compensated, load-sensing valves with circuit reliefs in all circuits

Undercarriage

- 6 x 4
- Wheelbase: 171" (4.34m)
- Width 102" (2.6m)
- Extended steps

Transmission

- Allison 3000 RDS 6-speed automatic.

Frame

- 48" (1.2m) wide, welded plate design
- 65 ksi material

Gross Vehicle Axle Weight Rating:

- 6 x 4 68,700 lbs (31,162 kg)

Front Axles

- 6 x 4: Meritor Model FL 941, 18,700 lbs (8,482 kg) rating

Rear Axle

- Meritor Model RT-50-160, 50,000 lb (22,680 kg) rating, 7.17 ratio
- Single reduction with driver controlled differential lock in front/rear
- Inter-axle differential with lock

Suspension

- Front: Eight leaf spring with automatic lock-out cylinders
- Rear: Hendrickson Equalizer Beam, 8" oscillation

Brakes

- 6 x 4 Front: Meritor "Q" Plus Series
 - Cam-Master Size: 16.5" x 5" (419 mm x 152 mm)
 - Automatic slack adjusters
- Rear: Meritor "P" Series
 - Cam-Master Size: 16.5" x 7" (419 mm x 178 mm)
 - Automatic slack adjusters
- Spring brake system incorporates emergency and parking brakes on the rear axle
- Heated air dryer

Steering

- Ross, integral hydraulic power steering
- Gear type power steering pump
- Four-quart power steering reservoir with filter
- 10 Micron pre-filter

Wheels

- Hub piloted disc
- 10-stud, 11.25" (286 mm) bolt circle

Tires

- 6 x 4 front: 385/65R22.5 LR (J) on/off highway tread
- 6 x 4 rear: 11R24.5 LR (H) on/off highway traction tread

Standard chassis equipment

- LED headlights
- LED tail lights
- LED back-up lights and alarm
- LED brake lights
- LED identification lights front and rear
- LED directional lights
- LED four-way hazard lights,
- Instrument panel lights
- Windshield wiper/washer
- West Coast style mirror system with plain and convex mirrors
- Front and rear tow hooks
- Desiccant type air dryer with automatic purge valve and thermostatically controlled heater
- FRA required directional lighting and change of direction alarm

Swing

- Internal swing gear
- Priority swing circuit with axial piston motor
- Planetary transmission

Swing Speed: 8.0 rpm

Swing Brake:

- Automatic spring-set/hydraulic release wet-disc parking brake
- Dynamic braking provided by hydraulic system

Chassis Cab

- One-person cab
- Left-hand mount
- Isolated from frame on rubber mounts
- Acoustical lining
- Sun visor
- FRA spec 360 degree strobe light
- Lower air horn
- Chassis camera
- Air conditioning

Gauge Clusters

- Oil pressure
- Coolant temperature
- Air tank pressures
- Fuel level
- DEF level
- Voltmeter
- Speedometer with odometer
- Tachometer with hour meter
- Engine and transmission monitor lights
- Engine shutdown controlled by engine electronics
- Indicator light and control for rear axle differential lock
- Park brake control
- Tinted safety glass
- Sliding side windows
- Fresh air heater and defroster
- Dome light
- Air suspension seat with seat belt
- Vent in door
- Dual air horn

GRADALL Model XL 5130 V Lift Capacity Over Side or Rear - LBS (KG)

LOAD POINT HEIGHT		LOAD RADIUS																								
		10' 0" (3.0 m)				15' 0" (4.6 m)				20' 0" (6.1 m)				25' 0" (7.6 m)				Max. Radius	On Tires		On Rails					
		On Tires		On Rails		On Tires		On Rails		On Tires		On Rails		On Tires		On Rails			Over End	Over Side	Over End	Over Side				
Over End	Over Side	Over End	Over Side	Over End	Over Side	Over End	Over Side	Over End	Over Side	Over End	Over Side	Over End	Over Side	Over End	Over Side	Over End	Over Side		Over End	Over Side	Over End	Over Side				
Above Ground Level	20' 0" (6.1 m)													5715 (2590)	5715 (2590)	5335 (2420)	5070 (2300)	5070 (2300)	5070 (2300)	4585 (2080)	29' 4" (8.3m)	5120 (2320)	5120 (2320)	5120 (2320)	3985 (1810)	
	15' 0" (4.6 m)					12425 (5635)	12425 (5635)	12425 (5635)	11485 (5210)	8795 (3990)	8795 (3990)	8795 (3990)	7495 (3400)	6515 (2955)	6515 (2955)	6515 (2955)	5265 (2390)	5230 (2370)	5230 (2370)	5230 (2370)	3670 (1665)	29' 5" (9m)	5265 (2390)	5265 (2390)	5265 (2390)	3620 (1640)
	10' 0" (3.0 m)									9880 (4480)	9880 (4480)	9880 (4480)	7340 (3330)	7140 (3240)	7140 (3240)	7140 (3240)	5165 (2345)	5230 (2370)	5230 (2370)	5230 (2370)	3670 (1665)	30' 6" (9.3m)	5265 (2390)	5265 (2390)	5265 (2390)	3620 (1640)
	BOOM LEVEL 8' 8" (2.7 m)									10080 (4570)	10080 (4570)	10080 (4570)	7290 (3305)	7255 (3290)	7255 (3290)	7255 (3290)	5135 (2330)	5230 (2370)	5230 (2370)	5230 (2370)	3670 (1665)	30' 7" (9.3m)	5265 (2390)	5265 (2390)	5265 (2390)	3620 (1640)
	5' 0" (1.5 m)									10290 (4665)	10030 (4550)	10290 (4665)	7135 (3235)	7415 (3365)	7175 (3255)	7415 (3365)	5040 (2285)	5230 (2370)	5230 (2370)	5230 (2370)	3670 (1665)	30' 7" (9.3m)	5375 (2440)	5195 (2355)	5375 (2440)	3915 (1775)
At Ground Level										9815 (4450)	9800 (4445)	9815 (4450)	6920 (3140)	7265 (3295)	7035 (3190)	7265 (3295)	4910 (2225)	5230 (2370)	5230 (2370)	5230 (2370)	3670 (1665)	29' 11" (9.1m)	5550 (2515)	5310 (2410)	5550 (2515)	3625 (1645)
Below Ground Level	5' 0" (1.5 m)					11090 (5030)	11090 (5030)	11090 (5030)	10150 (4605)	8705 (3950)	8705 (3950)	8705 (3950)	6740 (3055)	6745 (3060)	6745 (3060)	4785 (2170)	5230 (2370)	5230 (2370)	5230 (2370)	3670 (1665)	8.6m	5930 (2690)	5930 (2690)	5930 (2690)	5930 (2690)	
	10' 0" (3.0 m)	8500 (3855)	8500 (3855)	8500 (3855)	8500 (3855)	8630 (3915)	8630 (3915)	8630 (3915)	8630 (3915)	7365 (3340)	7365 (3340)	7365 (3340)	6600 (2995)	6010 (2725)	6010 (2725)	6010 (2725)	4685 (2125)	5230 (2370)	5230 (2370)	5230 (2370)	3670 (1665)	7.7m	5930 (2690)	5930 (2690)	5930 (2690)	5930 (2690)
	15' 0" (4.6 m)	5840 (2650)	5840 (2650)	5840 (2650)	5840 (2650)	6640 (3010)	6640 (3010)	6640 (3010)	6640 (3010)	6075 (2755)	6075 (2755)	6075 (2755)	6075 (2755)					5230 (2370)	5230 (2370)	5230 (2370)	3670 (1665)	7.0m	5930 (2690)	5930 (2690)	5930 (2690)	5930 (2690)
	20' 0" (6.1 m)	3930 (1780)	3930 (1780)	3930 (1780)	3930 (1780)														5230 (2370)	5230 (2370)	5230 (2370)	3670 (1665)	12' 10" (3.9m)	4875 (2210)	4875 (2210)	4875 (2210)

The rated lift capacity is based on the machine being equipped with 15,500 lb. (7030 kg) counterweight, standard boom and no bucket.

The load point is located on the bucket pivot point, including load listed for maximum radius.

Do not attempt to lift or hold any load greater than these rated values at specified load radii and heights. The weight of slings and any auxiliary devices must be deducted from the rated load to determine the net load that may be lifted.

ATTENTION: All rated loads are based on the machine being stationary and level on a firm supporting surface. For safe working conditions, the user must make allowance for his particular job conditions such as soft or uneven ground, out of level conditions, side loads, hazardous conditions, experience of personnel, etc. The operator and other personnel must be fully trained and understand the Operator's Manual and Safety Manuals furnished by the manufacturer before operating this machine. Rules for safe operation of equipment must be adhered to at all times.

Shaded areas are stability rated based on machine with 0 lb. bucket.

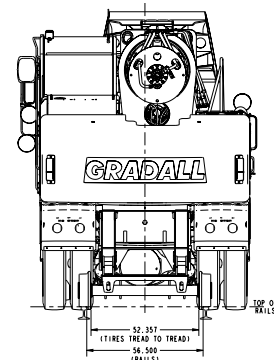
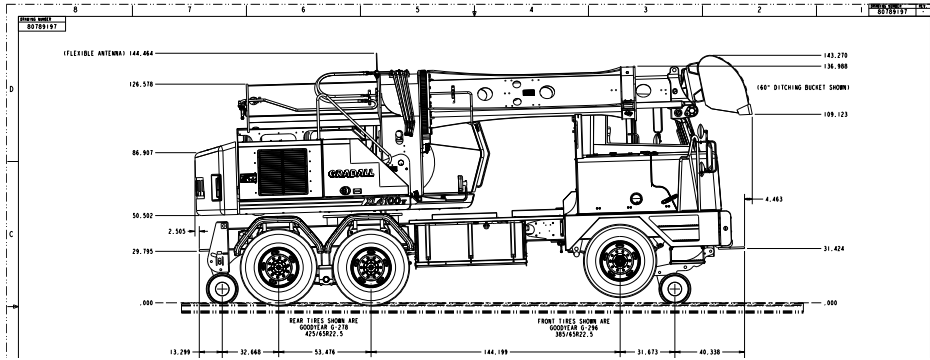
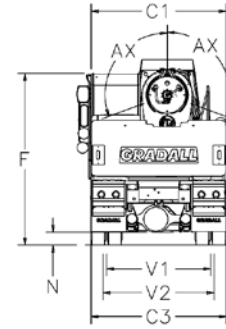
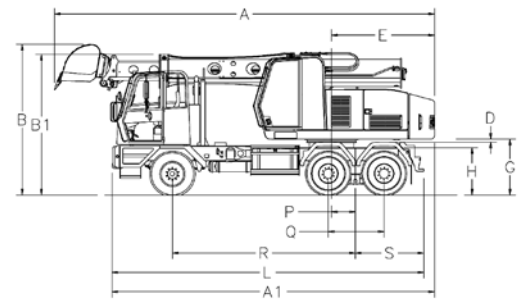
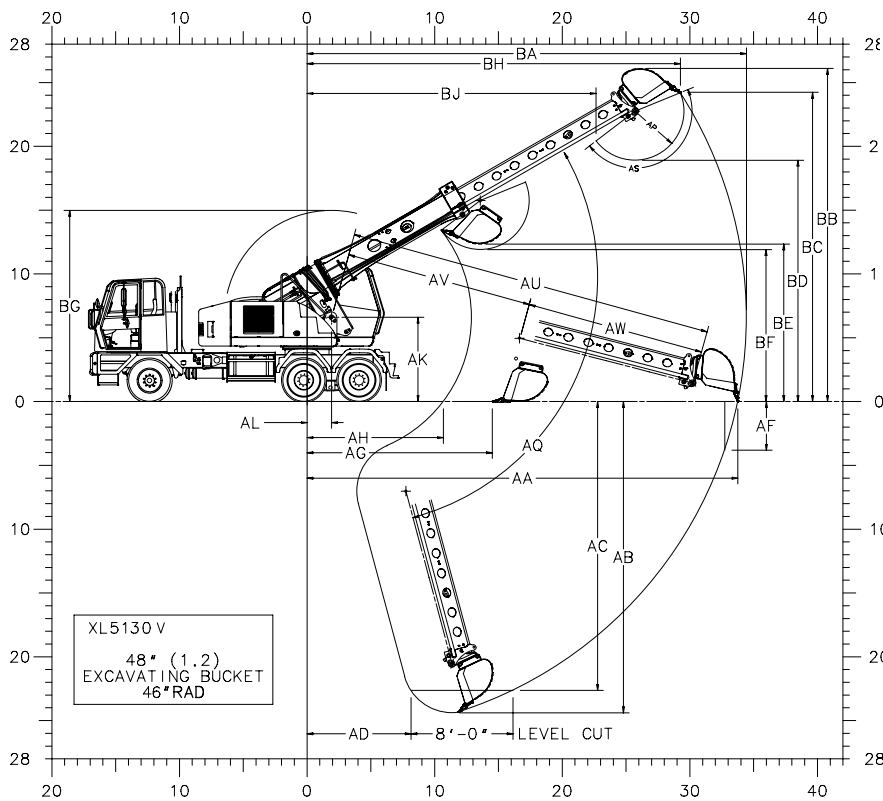

Dimensions

6 x 4

A	30' 5" (9.3m)	Overall length (boom in rack) with bucket
A1	25' 6" (7.8m)	Overall length (boom in rack) without bucket
B	11' 9" (3.6m)	Overall height (boom in rack) with bucket
B1	11' 2" (3.4m)	Overall height (boom in rack) without bucket
C1	8' 6" (2.6m)	Width of upperstructure
C3	8' 6" (2.6m)	Width of undercarriage
D	3" (76mm)	Minimum clearance, upperstructure to undercarriage
E	8' 6" (2.6m)	Swing clearance, rear of upperstructure
F	10' 10" (3.3m)	Top of cab to ground line
G	52" (1.3m)	Clearance upperstructure to groundline
H	44" (1.1m)	Top of wheel mounted under carriage frame to groundline
L	24' 2" (7.4m)	Overall length of undercarriage
N	10" (254mm)	Ground clearance (per SAE J1234)
P	22" (564mm)	Center of rear tandem to axis of rotation
Q	52" (1.3m)	Distance between centers of tandem axles
R	14' 3" (4.3m)	Wheelbase
S	5' 4" (1.6m)	Center of rear axle to rear of frame (step)
V1	6' 4" (2.0m)	Tread, rear axles (11R24.5 tires)
V2	7' 0" (2.1m)	Tread, front axle (385/65R22.5 tires)
AA	33' 9" (10.3m)	Maximum radius at groundline (165° pivot)
AB	24' 5" (7.4m)	Maximum digging depth
AC	22' 8" (6.9m)	Maximum depth for 8' level cut

6 x 4

AD	8' 7" (2.6m)	Minimum radius of 8' level cut at depth "AC"
AF	3' 10" (1.2m)	Maximum depth of vertical wall which can be excavated
AG	14' 6" (4.4m)	Minimum level cut radius with bucket flat on groundline
AH	10' 8" (3.3m)	Minimum radius at groundline
AK	6' 7" (2m)	Boom pivot to groundline
AL	23" (584mm)	Boom pivot to axis of rotation
AP	46" (511mm)	Bucket tooth radius
AQ	30° Up & 75° Down	Boom pivot angle
AS	165°	Bucket pivot angle
AU	28' 8" (8.7m)	Maximum telescoping boom length (boom pivot to bucket pivot)
AV	14' 8" (4.5m)	Minimum telescoping boom length (boom pivot to bucket pivot)
AW	14' 0" (4.3m)	Telescoping boom travel
AX	110°	Bucket tilt angle (both sides of center)
BA	34' 5" (10.5m)	Maximum radius of working equipment
BB	26' 1" (8.0m)	Maximum height of working equipment
BC	24' 3" (7.4m)	Maximum bucket tooth height
BD	18' 11" (5.8m)	Minimum clearance of bucket teeth, with bucket pivot at maximum height
BE	12' 4" (3.8m)	Minimum clearance of fully curled bucket at maximum boom height
BF	11' 11" (3.6m)	Minimum clearance of bucket teeth at maximum boom height
BG	15' 0" (4.6m)	Maximum height of working equipment with bucket below groundline
BH	29' 3" (8.9m)	Radius of bucket teeth at maximum height
BJ	22' 8" (6.9m)	Minimum radius of bucket teeth at maximum bucket pivot height

Specifications subject to change without notice.
Metric units are meters (m) unless noted.
Machines shown may have optional equipment.

Hydraulic Remote Control

- Upperstructure powered by chassis hydraulics through hydraulic motor and transfer case
- Travel and steering pedals in upperstructure cab
- Digging brakes and front axle lockout cylinders set automatically with travel pedal in neutral
- Parking brake controlled by toggle
- Electrically operated alarm mounted on undercarriage signals remote control movement in either direction, reverse movement when driven from undercarriage cab

Function Forces

Rated Boom Force: 24,500 lbs (109 kN)

Rated Bucket Breakout Force: 24,900 lbs (111kN)

Weight

- Approximate working weight, fuel tank half full - 6 x 4: 62,500 lb (28,350 kg)

Rail Gear

Guide wheel rail gear system allows the excavator to be propelled by the drive system of the machine

- DMF 1650 (50,000 lbs. each) Hi-Rail axle assemblies
- Railgear frame assemblies welded to main chassis frame
- 16" guide wheels (custom profile available)
- High-strength alloy steel axles
- Wheel brakes work in conjunction with excavator braking system
- Rear axles have 3" slotted suspension
- Rail sweeps front and rear
- Tow bar plates front and rear

Optional Equipment

- Vandalism protection kit including window covers
- Tilt steering column

Attachments

- Quick change and reversible buckets fabricated using steel plate with high strength, low alloy cutting edges and wear strips
- Standard attachments available for wide range of applications
- Capacities shown are in heaped cubic yard
- Excavating Buckets
- Trenching Buckets
- Pavement Removal Buckets
- Ditching Buckets
- Boom Extensions
- Tree Limb Shear
- Fixed Thumb Grapple
- Sleeper Changer
- Sleeper Layer
- Ballast Tamper
- Ballast Bucket
- Ballast Broom
- Ballast Blade
- Flail Mower
- Kinshofer NOX Rotator
- Single Tooth Ripper - 8065-5023

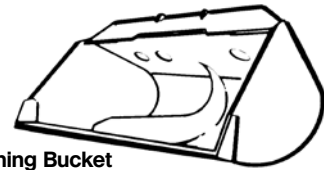

Ditching Bucket

		yd ³	m ³
8065-5037	48" (1.5m) 851 lbs (386 kg)		
8065-6007	60" (1.52m) 807 lbs (366 kg)	7/8	0.73
8065-6006	66" (1.68m) 892 lbs (405 kg)	1	0.76
8065-6002	72" (1.83m) 944 lbs (428 kg)	1 1/8	0.87
8065-6118	72" (1.83m) 1148 lbs (521 kg)	1.6	1.22

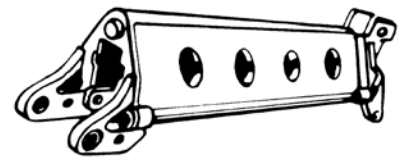

Boom Extension

8065-5028	4' (1.2 m) 1,090 lbs (495 kg)
8065-5029	6' (1.8 m) 1,250 lbs (560 kg)

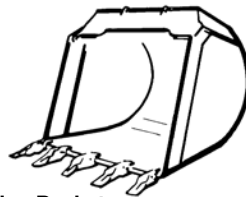

Excavating Bucket

		yd ³	m ³
8045-6020	24" (610mm) 603 lbs (274 kg)	3/8	0.31
8045-6021	30" (762mm) 660 lbs (300 kg)	1/2	0.41
8045-6022	36" (914mm) 741 lbs (336 kg)	5/8	0.54
8045-6023	42" (1,07m) 841 lbs (382 kg)	3/4	0.64
8045-6024	48" (1,22m) 957 lbs (434 kg)	1	0.76
8065-6117	48" (1,22m) 959 lbs (435 kg)	1.5	1.15

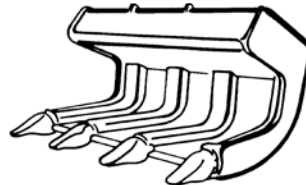

Pavement Removal Bucket

8065-6102	40" (1.0 m) 1262 lbs (573 kg)
8065-6119	48" (1.22 m) 1910 lb (866 kg)

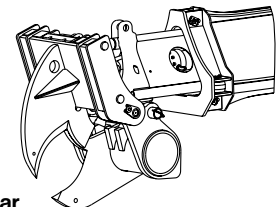

Tree Limb Shear

8045-5052	1,948 lbs (884 kg)
-----------	--------------------

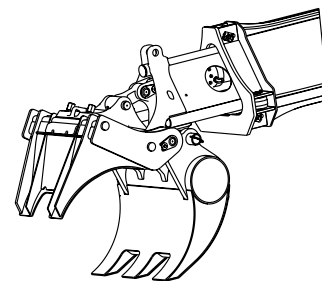

Fixed Thumb Grapple

8075-5023	1,574 lbs (714 kg)
-----------	--------------------

It is Gradall Policy to continually improve its products. Therefore designs, materials and specifications are subject to change without notice and without incurring any liability on units already sold. Units shown may have optional equipment.

GRADALL®

406 Mill Ave. SW, New Philadelphia, Ohio 44663
Phone: 800-445-4752 Fax: 330-339-8468
www.Gradall.com



Form No. 11827 12/19
Printed in USA